

ControlNet Network

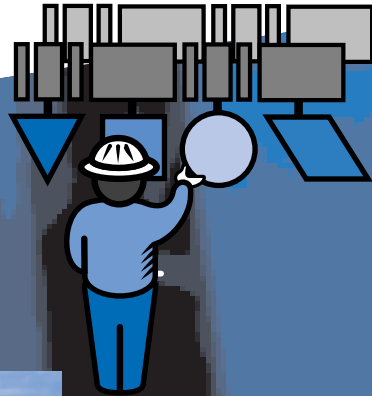

System Overview

Release 1.5



ControlNet

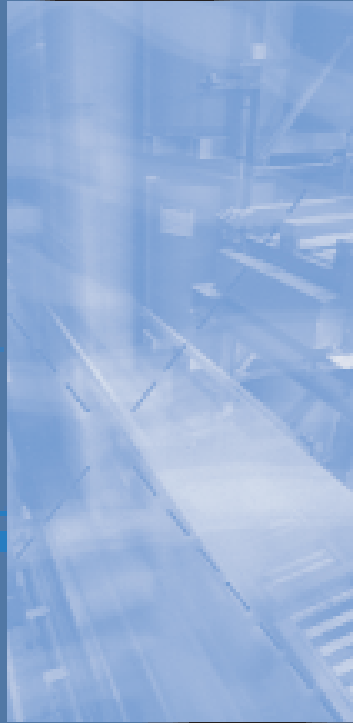

ControlNet Network System Overview

Introducing the ControlNet Network.....	2
The Producer/Consumer Model.....	6
Benefits of a Producer/Consumer-based Network	6
Information Exchange on a ControlNet Link.....	7
Sending Scheduled Data to and from a PLC-5.....	9
1771 and 1794 Modules.....	11
Other ControlNet Processors	13
Sending Unscheduled Data	13
I/O Scanning	14
Sending Immediate Data.....	15
Sending Forced Discrete I/O Data.....	16
Mapping ControlNet Discrete I/O Data.....	16
Reserving Space for Non-ControlNet I/O.....	16
Processor-Resident local I/O	16
Downloading Non-ControlNet PLC-5 Programs to a ControlNet PLC-5 Processor.....	17
ControlNet Media.....	18
Cables	19
Cable Connectors.....	19
Terminators	19
Tap Kits.....	20
Coax Repeaters.....	21
ControlNet Coax/Fiber Repeaters.....	21
Connector/Tool Kits	21
ControlNet Features	22
ControlNet Coax Repeater Modules.....	22
ControlNet Fiber Optic Repeater Modules.....	23
ControlNet Products.....	28
PLC-5 Programmable Controllers.....	29
FLEX I/O Adapter Module	32
1771 Adapter Modules	34
RS-232-C/Parallel Interface	36
ISA/EISA Bus Interfaces	38
RSNetWorx for ControlNet Configuration Software.....	40
RSLinx Software	41
RSLogix5 Programming Software	42

Introducing the ControlNet Network

The ControlNet network is a high-speed deterministic network used for the transmission of time-critical application information.

It provides real-time control and messaging services for peer-to-peer communication. As a high-speed link between controller and I/O devices, it combines the capabilities of existing networks.

ControlNet is a state-of-the-art open network providing:

- bandwidth for I/O, real-time interlocking, peer-to-peer messaging and programming—all on the same link
- deterministic, repeatable performance for both discrete and process applications

Release 1.5 takes full advantage of the producer/consumer network model by enabling:

- multicast of inputs
- multicast of peer-to-peer data

Windows™-based (95 and NT) configuration software is used with Release 1.5 functions and allow users to graphically view and configure the entire network.

The ControlNet product line offers everything from processors with integral ControlNet communications to I/O interfaces and interface cards for connecting personal computers.

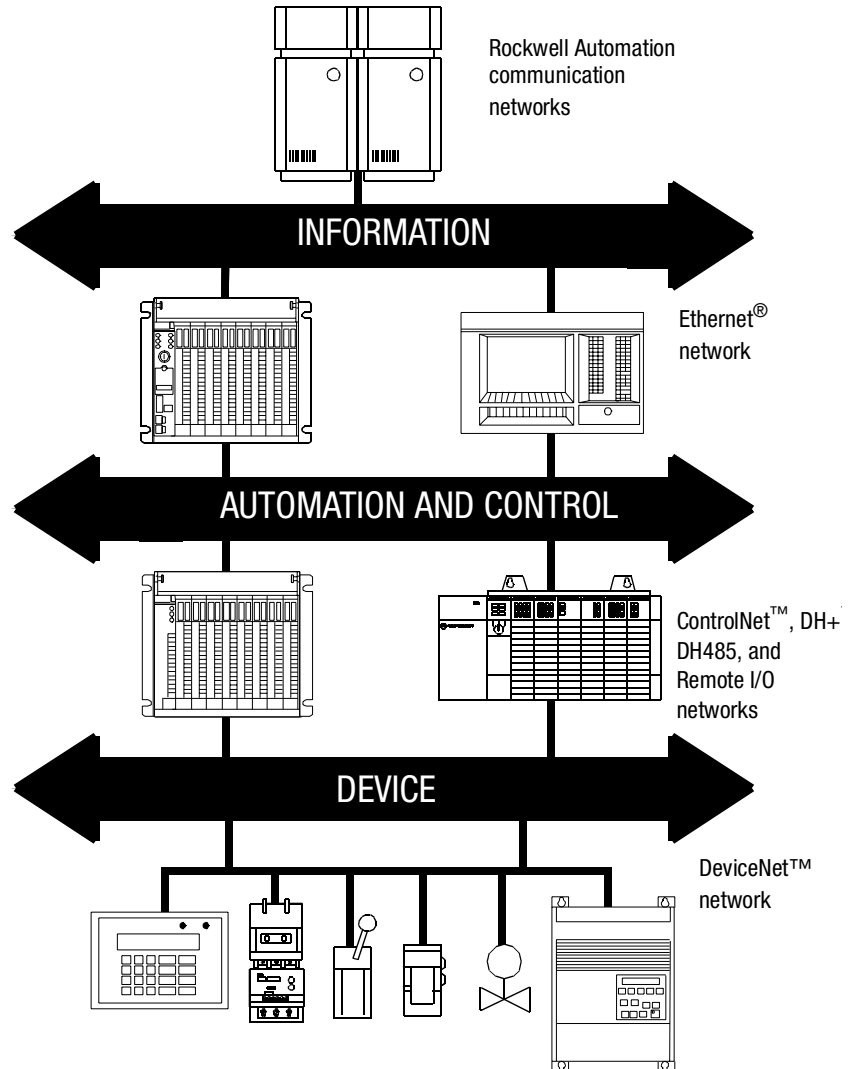

The Rockwell Automation/Allen-Bradley Network Architecture has three layers:

- Ethernet at Information Layer for plant-wide data collection and program maintenance
- ControlNet, DH+, DH485, and Remote I/O at Automation and Control Layer for real-time I/O control and controller interlocking and messaging
- DeviceNet at Device layer for cost-effectively integrating low-end devices

30073-M

Networking capabilities

- high throughput—5M bit/sec data rate for improved I/O, controller interlocking, and peer-to-peer messaging performance
- combine I/O control and programming on the same physical media link
- easy configuration and maintenance with increased diagnostics
- deterministic and repeatable data delivery
- multiple controllers controlling I/O independent of each other on the same link
- scheduled peer-to-peer interlocking between all controllers on the link
- multicast capabilities—multiple controllers sharing input data, and multiple controllers sharing peer-to-peer interlocking data for greater performance and reduced programming requirements

Reduced installation costs

- widely used RG-6 quad shield coax cable and connectors available from Allen-Bradley and other vendors
- taps with integrated drop cables for node connections—no minimum spacing required between taps

Simplified programming and network configuration

- user-selectable I/O and PLC interlocking update times to match application requirements
- on-line feedback of network bandwidth use
- configure I/O and PLC interlocking without programming ladder logic (no block-transfer programming)
- Network configuration software (RSNetWorx™ for ControlNet) that provides a graphical view of the network

Flexible architecture

- distances of 30 km or more using repeaters (star, tree, or bus)
- simplified design: no complex formulas to calculate cable distances (simple chart based on the number of taps and cable length)
- several cable options—including fiber optic for use in a wide range of applications and environments
- PLC processors with ControlNet, DH+, and Remote I/O ports, plus options to include Ethernet and DeviceNet
- compatible with a range of current and future Rockwell Automation products
- media layer redundancy (optional) for increased network reliability

Rockwell Automation/Allen-Bradley support and service

In today's competitive world, when you buy a product, you expect that product to meet your needs. You also expect the product's manufacturer to back it up with the kind of customer service and product support that prove you made a wise purchase.

As the people who design, engineer, and manufacture your industrial automation equipment, we at Allen-Bradley have a vested interest in your complete satisfaction with our products and services.

Call your Allen-Bradley representative for:

- sales and order support
- technical product training
- warranty support
- support service agreements

The ControlNet Network in Allen-Bradley Architecture

The ControlNet network is a high-speed deterministic network used for the transmission of time-critical application information. At the same time it also allows for transport of less time critical messaging data without impacting time-critical data transport.

It provides real-time control and messaging services for peer-to-peer communication. As a high-speed link between controller and I/O devices, it can combine the capabilities of existing Remote I/O and Data Highway Plus links.

A variety of devices can be connected to a ControlNet network, including personal computers, controllers, operator interfaces, drives, and other devices with ControlNet connections.

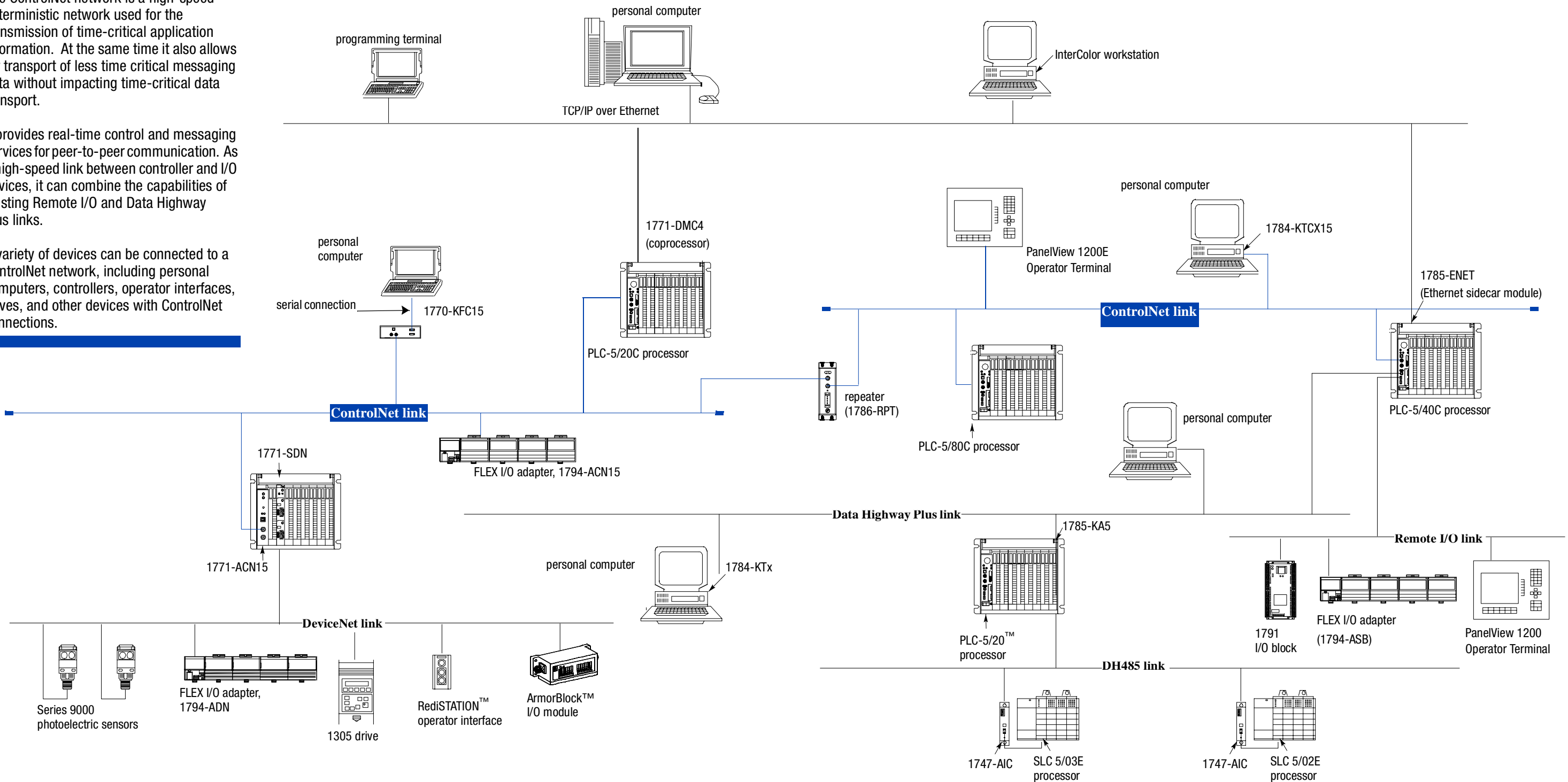

The Producer/Consumer Model

ControlNet is based on an innovative solution in open network technology—the Producer/Consumer model. The Producer/Consumer model permits all nodes on the network to simultaneously access the same data from a single source. Ultimately, the model provides: greater system performance, increased efficiency because data is produced only once regardless of the number of consumers, and precise synchronization because data arrives at each node at the same time.

The capabilities of traditional networks cannot satisfy the ever-increasing demands for higher productivity and greater system performance, while providing for repeatable and predictable communication between devices. Higher data rates and greater protocol efficiency are not enough to meet the challenge. A clean-slate approach is needed for the basic technology of how a network manages communications with connected devices (nodes). ControlNet is based on the most advanced communication technology—the Producer/Consumer Model.

Benefits of a Producer/Consumer-based Network

- Increased efficiency- The source sends data only once and multiple nodes can consume the data simultaneously. Messages are identified by content.
- Precise synchronization - More devices can be added to a network without necessarily increasing network traffic and data arrives at all nodes at the same time.

Producer/Consumer networks support:

- systems having master/slave, multimaster, or peer-to-peer communication
- hybrid systems (any mix of master/slave, multimaster, and peer-to-peer devices)
- any mix of message types (explicit messaging, I/O data) on one link

Data Packets as Processed by Network Models



Figure 1. Legacy Source/Destination Model

- Requires multiple packets to deliver the same message to multiple devices
- Data arrives at different times to different destinations
- Creates extra network traffic, impacting performance
- Different networks for messaging and time-critical I/O



Figure 2. Producer/Consumer Network Model

- Multiple nodes can consume the same data from a single producer
- Nodes can be synchronized (multicast)
- Optimized bandwidth potential for enhanced performance
- Same network for programming and I/O messages

Information Exchange on a ControlNet Link

A ControlNet link's most important function is to transport time-critical control information (i.e., I/O status and control interlocking). Other information (i.e., non-time-critical messages such as program uploads and downloads) is also transported but does not interfere with time-critical messages because of ControlNet's unique time-slice algorithm.

On a ControlNet link, information is transferred between nodes by establishing connections. Each message sent by a producer contains a Connection ID (CID). Nodes that have been configured to recognize the CID consume the message, therefore becoming a consumer.

Media access to the network is controlled by a time-slice access algorithm, Concurrent Time Domain Multiple Access (CTDMA), which regulates a node's opportunity to transmit in each network update interval (NUI). You configure how often the NUI repeats by selecting a network update time (NUT) in milliseconds. The minimum NUT you can specify is 2 ms. The NUT is divided into three parts:

This part of the NUT	allows
scheduled	every scheduled node (on a rotating basis in sequential order) one guaranteed opportunity to transmit. Information that is time-critical is sent during this part of the interval.
unscheduled	all nodes to transmit on a rotating basis in sequential order. This rotation repeats until the time allotted for this portion is used up. The amount of time available for the unscheduled portion is determined by the traffic load of the scheduled portion. ControlNet guarantees at least 1 node will have the opportunity to transmit unscheduled data every interval. Information that can be delivered without time constraints is sent during this part of the interval.
maintenance	the node with the lowest address to transmit information to keep the other nodes synchronized. This time is automatically subtracted from your NUT.

The complete NUT is the sum of scheduled, unscheduled, and maintenance messages sent. You configure the types of messages a node will transmit during the NUI (scheduled vs. unscheduled), while the maintenance time is automatically incorporated. See the following figure.

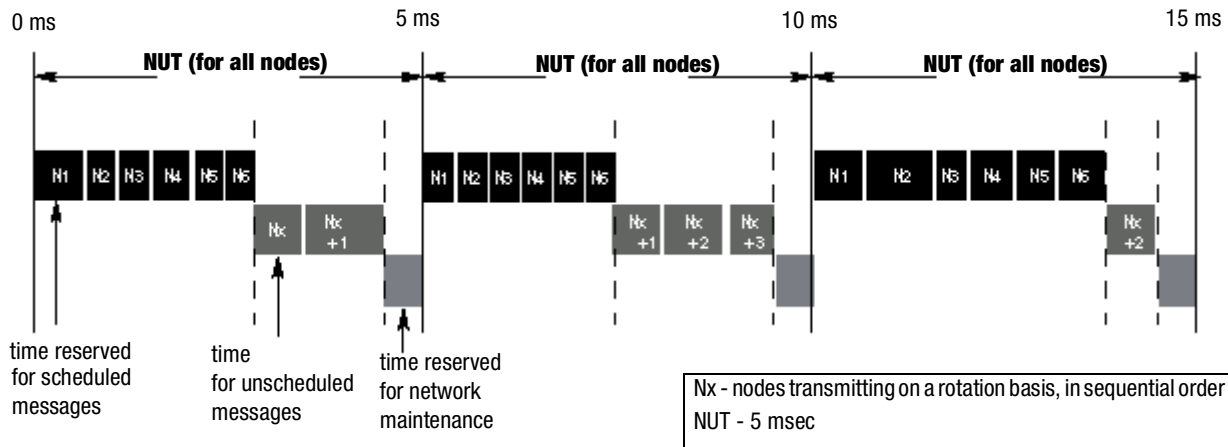

30100-M



For optimum performance, assign addresses to ControlNet nodes in a sequential order starting with 01 for a configuration keeper device (example, PLC-5).

For information on	See Page
sending scheduled data	9
sending unscheduled data	13
sending forced discrete I/O data	15
sending immediate data	15
mapping ControlNet discrete I/O data	16
reserving space for non-ControlNet I/O	16
downloading current PLC-5 programs to a ControlNet PLC-5 processor	17

Sending Scheduled Data to and from a PLC-5

You configure a maximum scheduled node which is the highest node that can send data during the scheduled portion of the network update time.

- ▶ ControlNet will reserve bandwidth in the scheduled portion for all nodes up to the specified maximum scheduled node. For an efficient network, assign node addresses sequentially starting at 01, and set your maximum scheduled node to the highest node number which will need to transmit scheduled data.

ControlNet scheduled data transfer:

- is continuous
- transmits asynchronously to the ladder-logic program scan
- occurs at a consistent rate that is as fast or faster (the same or better) than the rate that you specify in an I/O map-table entry

For scheduled data transfer, the following updates occur:

- the gathered input-image is moved from a private memory buffer to the processor's input-image file for use during the next logic scan
- the data from the output-image file is put into a private memory buffer and is sent during the next scheduled communication

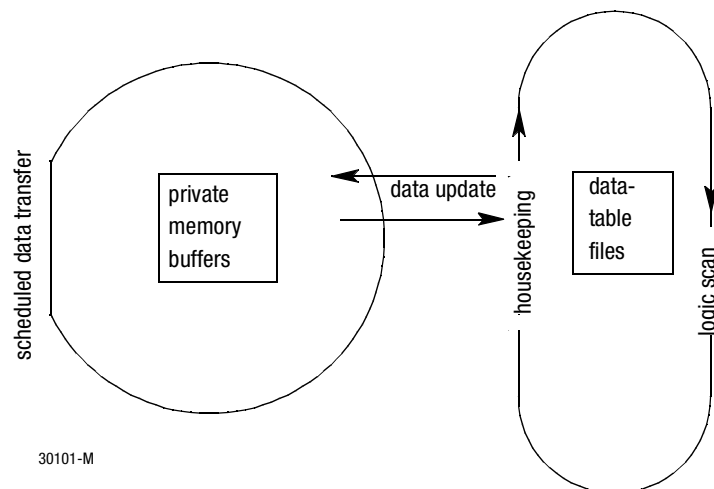

30101-M

PLC-5/20C, -5/40C, and -5/80C support these scheduled data-transfer operations on a ControlNet network:

Operation	Description
discrete I/O data transfer	Performed in a deterministic and repeatable manner asynchronous to and independent of the ladder-logic program scan. You configure all ControlNet discrete I/O data transfers on a per-node basis in the I/O map table. ^①
non-discrete I/O data transfer	Handled with the same priority as discrete I/O data transfer. You can update analog data without using block-transfer instructions in ladder programs by including non-discrete I/O data-transfer configurations in the I/O map table. This data is updated in the buffers and data-table files between logic scans in the same manner as that used in discrete I/O data transfer. ^①
peer-to-peer communication	Allows a ControlNet processor to communicate with any other ControlNet processor on the ControlNet network with the same priority as that of the discrete and non-discrete I/O data transfers discussed above. ^①

^① While scheduled data transfer is asynchronous to program scanning, all data is presented synchronously to the processor and output buffers during housekeeping.

All scheduled data transfers must be mapped on a ControlNet network. You specify where I/O data is to be read from or written to—i.e., mapped. You do this to establish the relationship between processors, I/O adapters, and data-table file addresses by creating and maintaining an I/O map table. A ControlNet processor can support up to 128 map entries, depending on the processor type.

An I/O map-table entry is required for each scheduled data transfer. The map table is stored in the configuration section of memory and is not accessible by your application program.

ControlNet non-discrete I/O data is stored in integer files that you specify in a ControlNet configuration screen. The ControlNet processor supports two distinct image files; both are integer data-table files that you specify:

- Data Input File (DIF)
- Data Output File (DOF)

Each map entry for a non-discrete I/O data transfer defines an offset into the Data Input File (DIF) or Data Output File (DOF) where the data is stored. Using separate data-table files for non-discrete I/O data transfer lets the processor present non-discrete I/O data in the same manner as discrete I/O data—continuously transmitted and asynchronous to the ladder-logic program image files.

1771 and 1794 Modules

ControlNet chassis discrete I/O data-transfer mapping requires one map entry per physical adapter. ControlNet non-discrete I/O data-transfer mapping requires one map-table entry per non-discrete module. The ControlNet processors' non-discrete I/O data-transfer mechanism makes it possible to eliminate block-transfer programming when communicating with these modules.

1771 Non-discrete I/O modules

Catalog number	Module
1771-CFM	1771-CFM Configurable Flowmeter module
1771-DB	PLC Basic Module
1771-DE	1771-DE Absolute Encoder module
1771-Generic ^①	1771-Generic module ^①
1771-IE	1171-IE Analog Input module
1771-IF	1771-IF Analog Input module
1771-IFE	1771-IFE Analog Input module
1771-IJ	1771-IJ Encoder/Counter module
1771-IK	1771-IK Encoder/Counter module
1771-IL	1771-IL Isolated Analog Input module
1771-IR	1771-IR RTD Input module
1771-IS	1771-IS Multiplexer Input module
1771-IXE	1771-IXE Thermocouple/Millivolt Input module
1771-IXHR	1771-IXHR High-resolution Thermocouple/Millivolt Input module
1771-OF	1771-OF Analog Output module
1771-OFE	1771-OFE Analog Output module
1771-QA	1771-QA Stepper Positioning module
1771-QB	1771-QB Linear Positioning module
1771-QC	1771-QC Servo Positioning module
1771-SN	1771-SN Sub I/O Scanner module
1771-VHSC	1771-VHSC Very High-speed Counter module
N-Series	1771-N-Series Analog modules

^① For newly released modules or modules that can have multiple configurations but only one configuration is being used, you can use the generic module type and specify the input and/or output sizes.

1794 Non-discrete I/O modules

Catalog number	Module
1203-FM1/A	SCANport module
1794-Generic ^①	1794 Generic module
1794-IA8	analog I/O module
1794-IB16	discrete input module
1794-IB8S	discrete input module
1794-IE4XOE2	analog I/O module
1794-IE8	analog input module
1794-IF4I	analog input module
1794-IJ2	intelligent module
1794-IR8	analog input module
1794-IT8	analog input module
1794-OA8	analog output module
1794-OB16	discrete output module
1794-OE4	analog output module
1794-OF4I	analog output module
1794-OW8	analog output module

^① For newly released modules or modules that can have multiple configurations but only one configuration is being used, you can use the generic module type and specify the input and/or output sizes.

Important: There are some special discrete modules that can be configured to exchange additional data beyond the discrete input/output status. These modules must be mapped similar to non-discrete module in order to exchange the extra status and configuration data.

The processor's non-discrete I/O data-transfer mechanism typically accommodates modules that require a one-time configuration and then continuously read or write.

By using ControlNet I/O Transfer instructions (CIO), you can also send unscheduled data transfers to communicate with 1771 and 1794 modules.

Other ControlNet Processors

ControlNet scheduled peer-to-peer communication between ControlNet processors requires one map entry per message.

ControlNet peer-to-peer communications between any two processors can be set up on a ControlNet network. The ControlNet transfer mechanism makes it possible to map the following scheduled peer-to-peer messages:

Message	Description	Valid Input
		Sizes
receive data from	scheduled message	1-240 words
send data	scheduled message	1-240 words

Sending Unscheduled Data

A ControlNet link lets you use unscheduled messaging when deterministic delivery is not required. Unscheduled operations include:

- unscheduled non-discrete I/O data transfers—through ControlNet I/O Transfer instructions (CIOs) in the PLC ladder program
- peer-to-peer messaging—through Message instructions (MSGs) in the PLC ladder program

Unscheduled transfers are performed during the unscheduled time in the network update interval.

Unscheduled messaging on a ControlNet network is non-deterministic. Your application and your configuration—number of nodes, application program, Network Update Time (NUT), etc.—help determine how much time there is for unscheduled messaging.

Important: The ControlNet configuration software (RSNetWorx) reserves time for at least one maximum-sized unscheduled transfer per NUI. Depending on how much time there is for unscheduled messaging, each node may not have a chance to send unscheduled data every NUI.

I/O Scanning

The following figure shows ControlNet-I/O scan and controller-program scan loops for scheduled data.

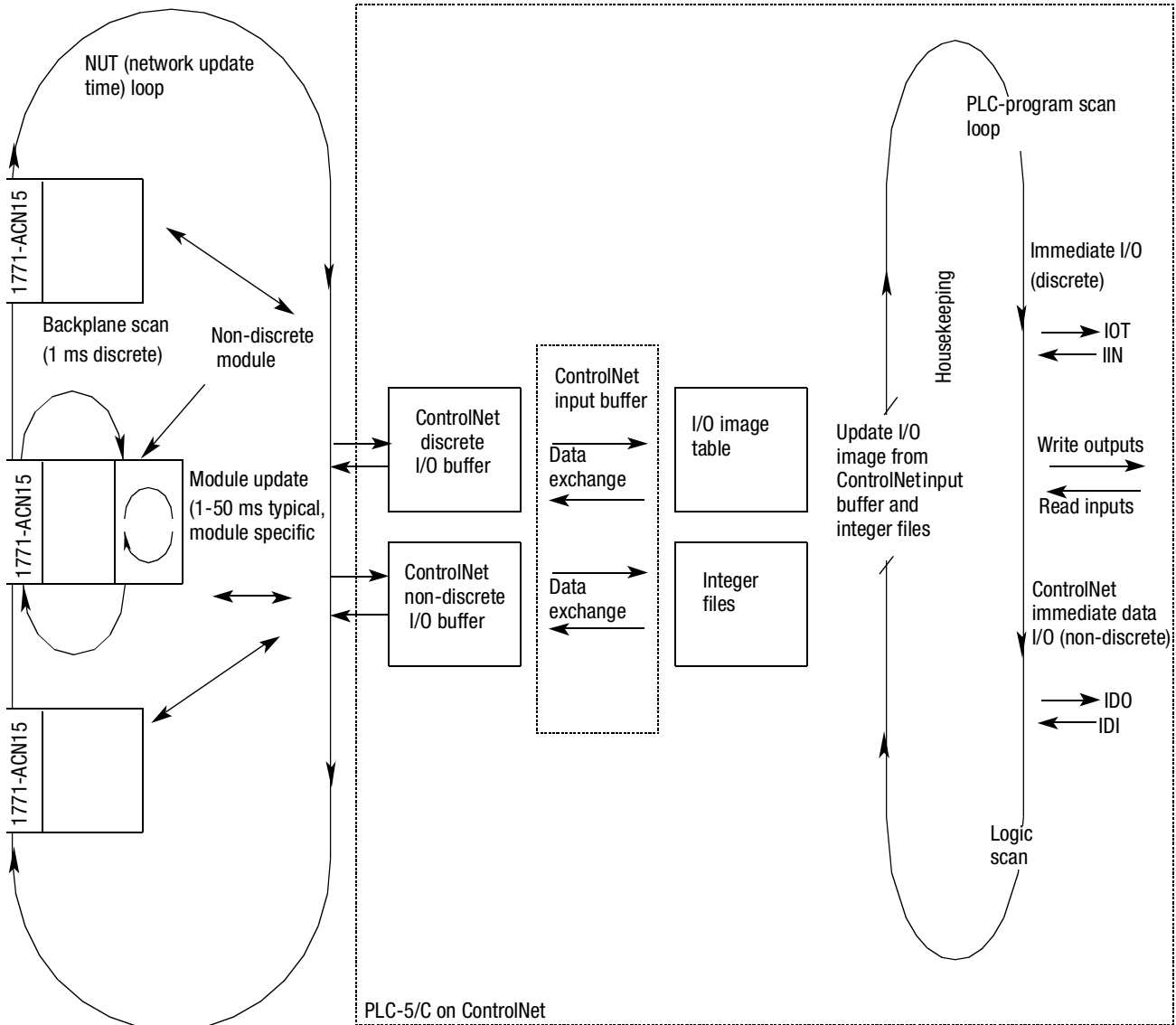

Module update time varies with:

- module type (module scan)
- number of block transfers at node

30104-M

Sending Immediate Data

ControlNet immediate data transfers perform similarly to remote-I/O immediate I/O transfers—the logic scan is temporarily interrupted while the most recent state of up to 64 words is read from or written to the private memory buffer.

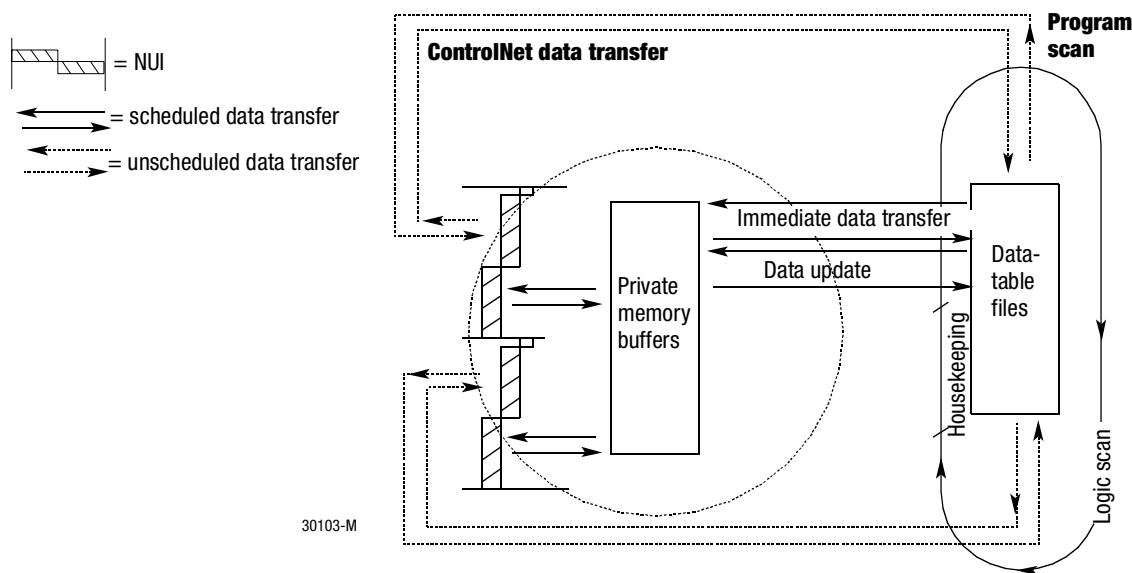

On a ControlNet link, you can use these immediate I/O instructions.

Instructions	Used to
Immediate I/O	transfer 1 word of discrete I/O data.
ControlNet and Remote I/O	In an immediate-input instruction (IIN), the most recent copy of the specified input word secured in the last discrete I/O data transfer from the corresponding I/O chassis is used. This value is moved from the private memory buffer to the working data table and is used in all subsequent ladder instructions. <i>This data could be as old as the time taken since the last asynchronous I/O update, and it may not actually reflect the latest state of the input word.</i>
001 —(IIN)— 001 —(IOT)—	In an immediate-output instruction (IOT), the current state of the specified output word is copied to the private memory buffer and is used on the next output update to the I/O chassis. The actual change is not communicated until the next asynchronous I/O update.
ControlNet Immediate Data I/O	transfer as many as 64 words of non-discrete I/O data.
IDI	The ControlNet immediate data I/O instructions (IDI and IDO) work in much the same way as the immediate I/O instructions. In an input instruction (IDI), the most recent data is copied from the private memory buffer to a data-table address that you specify. <i>This data could be as old as the time taken since the last asynchronous I/O update, and it may not actually reflect the latest state of the input word.</i>
IMMEDIATE DATA INPUT	
Data file offset	232
Length	10
Destination	N11:232
IDO	In an output instruction (IDO), the data is copied from an area that you specified to the private memory buffer and sent on the next I/O update. <i>The actual change is not communicated until the next asynchronous I/O update.</i>
IMMEDIATE DATA OUTPUT	
Data file offset	175
Length	24
Source	N:12:175

Sending Forced Discrete I/O Data

ControlNet I/O forcing occurs in the same way as remote I/O forcing in standard processors. The processor performs the forcing and transmits the forced data to the output- and input-image tables. You can force any discrete I/O data placed in the I/O image.

Mapping ControlNet Discrete I/O Data

Scheduled data transfers must be mapped on a ControlNet network. You specify where I/O data is to be read from or written to, or mapped. This establishes a relationship between processors, I/O adapters, and data-table file addressing by creating and maintaining a map table. The map table is stored in the configuration section of memory and is not accessible by your application program.

Using programming software, you can automatically configure and map nodes attached to your ControlNet I/O.

Reserving Space for Non-ControlNet I/O

Non-ControlNet processor-resident local I/O and remote I/O devices can only use fixed I/O image locations based on rack number for discrete I/O data transfer. Discrete input data from ControlNet nodes can be mapped to any unused location in the input image table or the Data Input File (DIF). Discrete output data to ControlNet nodes can be mapped to any unused location in the output image table or the Data Output File (DOF).

Before mapping your ControlNet I/O, you should configure any processor-resident local I/O and any remote I/O racks on non-ControlNet channels. This allows the programming software to reserve input- and output-image space for all non-ControlNet processor-resident local I/O and remote I/O chassis.

Processor-Resident local I/O

The following table shows the default number of input and output words automatically reserved by programming software for the different sizes and addressing modes of processor-resident local I/O:

Addressing mode	Number of words reserved			
	4 slots	8 slots	12 slots	16 slots
2-slot	8	8	8	8
1-slot	8	8	16	16
1/2-slot	8	16	24	32



ControlNet I/O cannot map into any part of a rack number used by the processor-resident rack.

Downloading Non-ControlNet PLC-5 Programs to a ControlNet PLC-5 Processor

When you download archived files from a non-ControlNet processor to a ControlNet processor, the processor ignores any Channel 2 configuration contained in the archived file. The software requires you to set Channel 2 to the default ControlNet configuration or preserve the current ControlNet information in the processor.

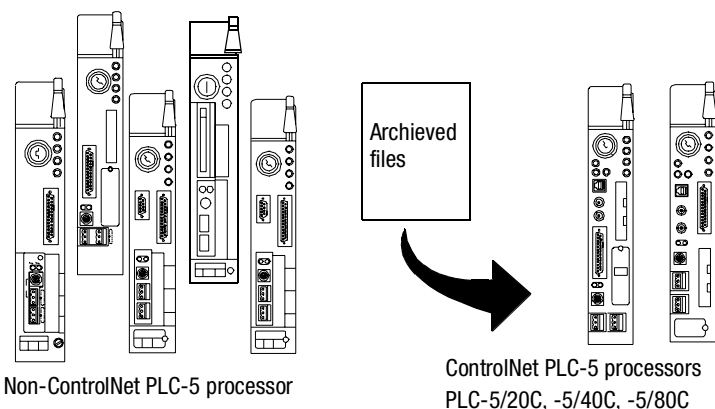

30105-M

Program files ^① for this process	Archived from a	On channel	Can be run on a PLC-5/C channel	If they fit and are		
	<ul style="list-style-type: none"> • PLC-5/11 (channels 0 and 1A only) • PLC-5/20 • PLC-5/20E • PLC-5/30 	<ul style="list-style-type: none"> • PLC-5/40 • PLC-5/40E • PLC-5/40L 	0	0	downloaded unchanged	
			1A	1A		
		<ul style="list-style-type: none"> • PLC-5/60 • PLC-5/60L • PLC-5/80 • PLC-5/80E 	1B	2	1B	performed by the ControlNet network—you must make these changes manually by reprogramming ^{② ③ ④}
				2	2	
messaging and I/O	<ul style="list-style-type: none"> • PLC-5/40 • PLC-5/60 	<ul style="list-style-type: none"> • PLC-5/80 	2A or 2B	1A or 1B	performed by DH+ or remote I/O—you must make these changes manually by reprogramming ^⑤	
				1A or 1B	performed by remote I/O—you must make these changes manually by reprogramming ^⑤	
	<ul style="list-style-type: none"> • PLC-5/20E • PLC-5/40E • PLC5/40L 	<ul style="list-style-type: none"> • PLC-5/60L • PLC-5/80E 	2	2	performed by the ControlNet network—you must make these changes manually by reprogramming ^{③ ④ ⑤}	

① These include processor files, data-table files, and port configurations.

② If you do not update the program, the ControlNet processor will fault.

③ You must change block-transfer instructions for the ControlNet system from the standard block-transfer-read (BTR) and block-transfer-write (BTW) instructions to scheduled transfers or to unscheduled ControlNet I/O transfer (CIO) instructions.

④ You must edit non-ControlNet PLC-5 programs containing references to the I/O status file for use with I/O connected via the ControlNet network. Information regarding ControlNet status is stored in a separate data file that you specify in your programming software.

⑤ If you do not update the program, the data-table locations corresponding to the “missing” I/O devices will not be updated.

ControlNet Media

This figure defines the components of the ControlNet Media

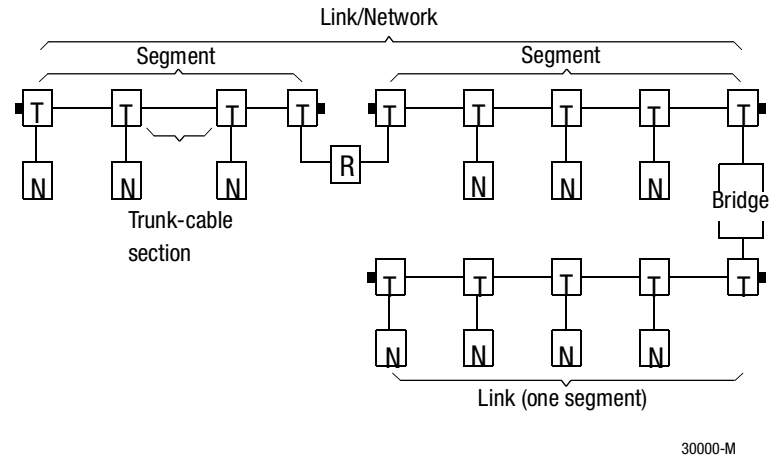

Network	a collection of connected nodes—the connection paths between any pair of devices may include repeaters and bridges
Link (multi-segment)	a collection of nodes with unique addresses in the range of 1-99; a link is comprised of one or more segments
Segment	trunk-cable sections connected via taps with terminators at each end and no repeaters
Trunk cable	the bus or central part of a cable system
Trunk-cable section	a length of coax or fiber cable between any two taps
Repeater (R)	a two-port active physical layer component that reconstructs and retransmits all traffic it hears on one segment side to another segment side
Tap (T)	the connection between any device and the ControlNet network Taps connect devices to the trunk cable.
Bridge	a device that lets traffic pass from one link to another link
Node (N)	any physical device connecting to the ControlNet cable system that requires a network address in order to function on the network—a link may contain a maximum of 99 nodes
Terminator (■)	a 75Ω resistor mounted in a BNC plug

Important: The ControlNet network is a ground-isolated coaxial or fiber network. Make sure you select proper cable, connectors, and accessories. Use proper installation techniques to make sure the network is not accidentally grounded.





For more information on ControlNet cables and system planning, see the ControlNet Cable System Planning Installation Guide, publication 1786-6.2.1.

Cables

There are several types of coax and fiber cables that may be appropriate for your installation, depending on the environmental factors associated with your application and installation site.

Cable Connectors

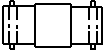
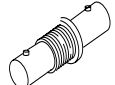
A cable connector attaches trunk-cable sections to the tap's BNC connector. Allen-Bradley offers optional cable connectors for use in your network configuration.

Description	Quantity	Part Number	
75 Ω cable crimp connector (cable connector) for attaching trunk-cable sections to a tap's BNC connector	50	1786-BNC	
75 Ω cable crimp jack-to-jack connector (bullet or jack-to-jack) for reserving a space in the trunk cable for future installation of a tap or to splice a trunk cable	50	1786-BNCJ	
75 Ω isolated bulkhead connector for allowing ControlNet cable trunk lines to pass through metal enclosures	5	1786-BNCJI	
75 Ω cable crimp male-to-male plug connector (barrel or plug-to-plug) to go through grounded panel walls while maintaining the shield isolation of the trunk-cable	50	1786-BNCP	

Terminators

75 Ω terminators, placed at the end of each segment, allow the ControlNet cable system to work.

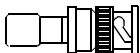
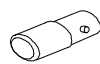
Description	Quantity	Part Number	
75 Ω coax trunk terminator plug	50	1786-XT	
Dummy load for unused tap drop cables	5	1786-TCAP	

Tap Kits

Taps connect devices (nodes or repeaters) to the network via an integral 1-m (39.6 in) drop cable. The number of taps you need depends on the number of devices you want to connect to the network.

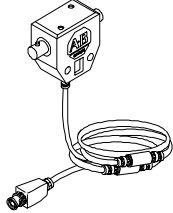
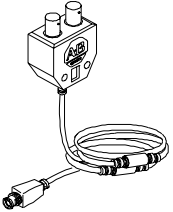
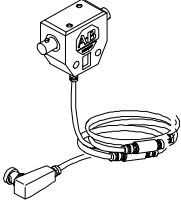
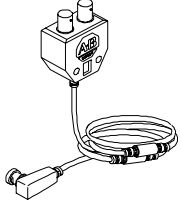
Description	Part Number	
Coax T-tap with straight BNC connector	1786-TPS	
Coax Y-tap with straight BNC connector	1786-TPYS	
Coax T-tap with right angle BNC connector	1786-TPR	
Coax Y-tap with right angle BNC connector	1786-TPYR	

Coax Repeater

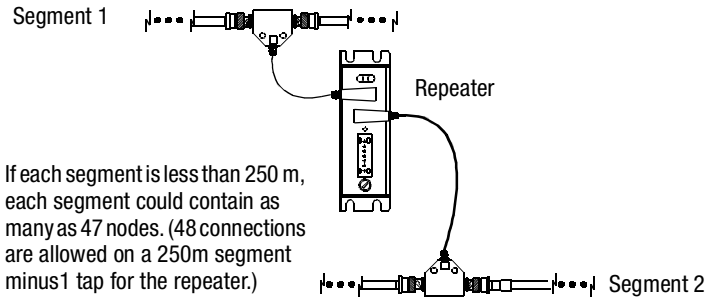

30016-M

ControlNet coax repeaters provide:

- an internal power supply
- a replaceable fuse for over-current protection
- two indicators for status and troubleshooting
- a fault-rely contact for status indications or switching to a backup repeater

ControlNet Coax/Fiber Repeaters

Description	Specifications/Distance	Part Number
Coax panel mount repeater high voltage ac/dc	85-250 V ac or 110-250 V dc	1786-RPT
Coax panel mount repeater 24vdc	20-72 V dc	1786-RPTD
Modular repeater adapter	Required to connect 1786-RPFS or -RPFM modules to Coax ControlNet network	1786-RPA
Short distance fiber module (uses pre-cut/pre-terminated cables)	up to 300m ^②	1786-RPFS
Medium distance fiber module (uses industry standard 62.5 micron fiber)	up to 3 km ^①	1786-RPFM

^① Refer to publication 1786-5.12, ControlNet Modular Repeater Short-distance Fiber Module Installation Instructions for information on longer distances

^② Refer to publication 1786-5.11, ControlNet Modular Repeater Medium-distance Fiber Module Installation Instructions, for information on longer distances

Connector/Tool Kits

Description	Part Number
Coax media tool kit (75Ω cable crimp tools)	1786-CTK
Connector kit for 500m bulk fiber cable and 1786-RPFS	1786-FSKIT

ControlNet Coax Repeater Modules

ControlNet Coax Repeater Modules (1786-RPT15, -RPTD15) are devices used to increase the number of nodes, extend the total length of your segment, or create a star or tree configuration. The number of repeaters you can use depends on your network topology.

ControlNet Features

- An internal power supply
- A fuse (replaceable) for over-current protection
- Two indicators for status and troubleshooting
- Extends the allowable cable length
- Fault-relay contact for status indication or switching to a backup repeater

Related Publications

Publication number	Title
1786-5.8	ControlNet Coax Repeater Installation Instructions
1770-4.1	Industrial Automation Wiring and Grounding Guidelines
1786-6.2.1	ControlNet Cable System Planning and Installation Guide



Ordering Information

The 1786-RPT15, -RPTD15 modules require the following:

- Two taps (1786-TPS, -TPYS, -TPR, -TPYR) per link
- Cable connectors (1786-BNCJ, -BNCP, -BNCJI)

Specifications

1786-RPT15, -RPTD15 Specifications

Power Requirements	1786-RPT15 85-250V ac, 47-63Hz, 60mA maximum 110-250V dc, 25mA maximum 1786-RPTD15 20-72V dc, 100mA maximum
Fault Relay Requirements	132V ac, 150mA maximum or 186V dc, 150mA maximum
Replacement Fuse	1786-RPT15 1/4A, 250V 3AG 1786-RPTD15 2A, 250V (slow-blow)
Environmental Conditions	Operating Temperature 0 to 60°C (32 to 140°F) Storage Temperature -40 to 85°C (-40 to 185°F) Relative Humidity 5 to 95% noncondensing
Agency Certification	<ul style="list-style-type: none"> •  •  marked for all applicable directives

ControlNet Features

- Ability to mix media types on the same repeater
- 24V dc power supplied through connection to the adapter (1786-RPA)
- DIN-rail mountable
- Extends the physical length of the network using fiber media

Product Features

- Diagnostic status on every port
- Provides intrinsically safe option
- Outdoor cable routing option
- High-noise immunity

ControlNet Fiber Optic Repeater Modules

The ControlNet Fiber Optic Repeater Modules family consist of an adapter (1786-RPA) and two types of repeaters (1786-RPFS, -RPFM). An adapter is need to connect modules to the ControlNet Network. After the adapter is installed, up to four modules in any combination of the two fiber repeaters can be installed.



Related Publications

Publication number	Title
1786-5.13	ControlNet Modular Repeater Installation Instructions
1786-5.12	ControlNet Modular Short-distance Fiber Module Installation Instructions
1786-5.11	ControlNet Modular Medium-distance Fiber Module Installation Instructions



Ordering Information

The 1786-RPA, -RPFS, -RPFM modules require the following:



- Coax cable - 1786-RG6
- use NEC/CEC Class 2 power supply to comply with UL and CSA requirements

1784-RPA, -RPFS Specifications

1786-RPA Specifications

Input Voltage Rating	24v dc nominal
Input Voltage Range	18.0V to 36.0V dc
Communication Rate	5M bits/s
Repeater Backplane Output Current	1.6A maximum @5V dc
Isolation Voltage	100% tested as 850v dc for 1s between user power and repeater backplane connections
Power Consumption	700mA maximum from external 24V supply based on worst case module loading
Environmental Conditions:	0 to 60°C (32 to 140°F)
Operating Temperature	-40 to 85°C (-40 to 185°F)
Storage Temperature	5 to 95% noncondensing
Relative Humidity	Operating - 30g peak acceleration, 11(±1)ms pulse width
Shock	Non-operating - 50g peak acceleration, 11(±1)ms pulse width Tested 5g @10-500Hz per IEC 68-2-6
Vibration	
ControlNet Coax Cable	1786-RG6
Power Conductors	
Wire Size	12 gauge maximum, 28 gauge minimum
Mounting Dimensions (H x W x D)	90 x 100 x 69 mm 3.6 x 4.0 x 2.76 in
Agency Certification	<ul style="list-style-type: none"> •   • CE marked for all applicable directives

1786-RPFS Specifications

Communication Rate	5M bits/s
Indicators	Channel 1 Status - green Channel 2 Status - green
Backplane Power Requirements	300 mA maximum
Environmental Conditions	0 to 60°C (32 to 140°F)
Operating Temperature	-40 to 85°C (-40 to 185°F)
Storage Temperature	5 to 95% noncondensing
Relative Humidity	Operating - 30g peak acceleration, 11(±1)ms pulse width
Shock	Non-operating - 50g peak acceleration, 11(±1)ms pulse width Tested 5g @10-500Hz per IEC 68-2-6
Vibration	
Fiber Type	200/230 micron HCS (hard-cold silica)
Fiber Termination Type	Versalink V-System
Fiber Operating Wavelength	650 nm (red)
Optical Power Budget	4.2 dB
Mounting Dimensions (H x W x D)	90 x 100 x 69 mm 3.6 x 4.0 x 2.76 in
Agency Certification	<ul style="list-style-type: none"> •   • CE marked for all applicable directives

1786-RPA

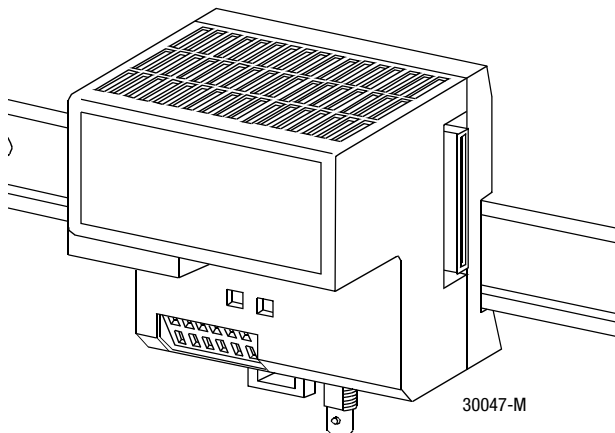

1786-RPFS

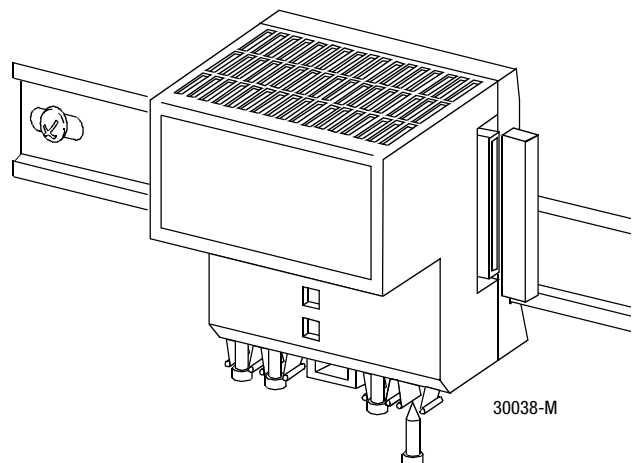

1786-RPFM Specifications

1786-RPFM Specifications

Communication Rate	5M bits/s
Indicators	Channel 1 Status - green Channel 2 Status - green
Backplane Power Requirements	400 mA maximum
Environmental Conditions	
Operating Temperature	0 to 60°C (32 to 140°F)
Storage Temperature	-40 to 85°C (-40 to 185°F)
Relative Humidity	5 to 95% noncondensing
Shock	Operating - 30g peak acceleration, 11(±1)ms pulse width Non-operating - 50g peak acceleration, 11(±1)ms pulse width
Vibration	Tested 5g @10-500Hz per IEC 68-2-6
Fiber Type	62.5/125 micron
Fiber Termination Type	ST [®] (plastic or ceramic)
Fiber Operating Wavelength	1300 nm
Optical Power Budget	13.3 dB ^①
Mounting Dimensions (H x W x D)	90 x 100 x 69 mm 3.6 x 4.0 x 2.76 in
Agency Certification	 CE marked for all applicable directives

^① This includes all loss associated with the fiber link, including: splices, fiber attenuation, bulkhead connectors, and the 1786-RPFM ST terminators

1786-RPFM

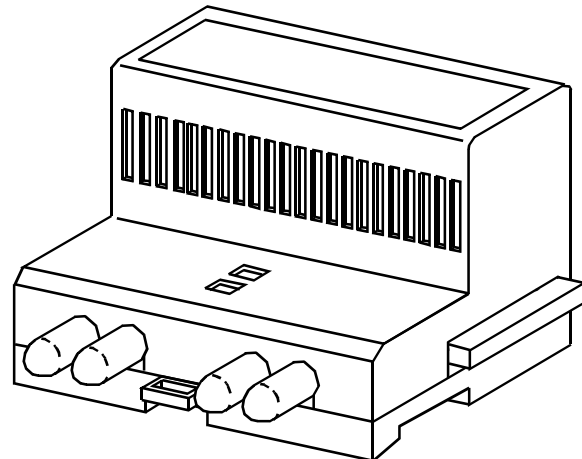

30042-M

Media Summary

General Planning

- the ControlNet cable system is isolated from earth and must be protected from inadvertent ground connections
- use the ControlNet toolkit (1786-CTK) to easily cut, strip, and terminate media connections

Segment Planning

- all connections to the trunk cable require a tap
- taps may be installed at any location on the trunk cable
- tap drop cable length is fixed at 1 m (3 ft)
- maximum number of taps is 48, with 250 m (820 ft) of trunk cable
- maximum trunk-cable length is 1000 m (3280 ft), with 2 taps
- 75 Ω terminators are required on both ends
- unconnected drop cables require a tap dummy load (1786-TCAP)
- do not mix redundant and non-redundant nodes for redundant operation
- avoid high-noise environments when routing coax cables
- NAP cables (1786-CP) fixed at 3m

Link Planning

- maximum of 99 nodes (excluding repeaters)
- repeaters require a tap but are not counted as nodes—they are included in the number of taps allowed per segment (48)
- repeaters may be installed at any tap location along a segment
- there can be only one path between any two points on a link
- the configuration of both sides of a redundant link must be the same
- the total cable difference between the two sides of a redundant link cannot exceed 800 m (2640 ft)

Coax Summary

Item		Catalog number	Descriptions/Information
Taps	straight T-tap straight Y-tap right-angle T-tap right-angle Y-tap	1786-TPS 1786-TPYS 1786-TPR 1786-TPYR	Use a tap for each connection to the trunk cable (nodes and repeaters). Each tap kit contains: two BNC connector kits, one dust cap, one universal mounting bracket and two screws.
Repeaters	85 - 250 V ac or 110 - 250 V dc 20-72 V dc	1786-RPT 1786-RPTD	Use a repeater to: <ul style="list-style-type: none"> increase the number of nodes attached extend the allowable cable length
Terminators		1786-XT	You need a terminator for each end of each segment.
Tap dummy load		1786-TCAP	Allows extra taps in a trunk line without installing nodes
Network access cable		1786-CP	Use this cable to temporarily connect programming devices (with 1786-KTC installed) to nodes.
Cable crimp connector		1786-BNC	Two cable connectors are shipped with each tap—order additional cable connectors for each bullet and isolated-bulkhead connector you'll be using.
Optional cable connectors	jack-to-jack male-to-male isolated-bulkhead	1786-BNCJ 1786-BNCP 1786-BNCJI	Attaches trunk-cable sections to the tap's BNC connector
Trunk cable		1786-RG6 1786-RG6F 1786-CP	Coax quad shield cable (1,000 ft) Coax quad shield high flex cable (1,000 ft) ControlNet network access cable, 3.05M (10 ft)
ControlNet toolkits		1786-CTK	Contains tools for cutting, stripping, and terminating media connections.

Fiber Summary

Item	Catalog number	Descriptions/Information
Repeaters	1786-RPA	Modular repeater adapter
	1786-RPFS	Short distance (up to 300m) fiber module (uses pre-cut/pre-determined cables listed below)
	1786-RPFM	Medium distance (up to 3 Km) fiber module (uses industry standard 62.5 micron fiber)
Fiber cable (for 1786-RPFS)	1786-FS10	10 m fiber cable assembly
	1786-FS20	20 m fiber cable assembly
	1786-FS60	60m fiber cable assembly
	1786-FS100	100m fiber cable assembly
	1786-FS200	200 m fiber cable assembly
	1786-FS300	300 m fiber cable assembly
	1786-FSB500	500 m bulk fiber cable
ControlNet toolkits	1786-FSKIT	Connector kit for 500 m bulk fiber cable and 1786-RPFS

ControlNet Products

On a ControlNet link, A-B offers PLC-5 processors with built-in ControlNet adapters for I/O products and communication interfaces for personal computers.

The ControlNet network's physical layer is coaxial or fiber cable with redundant media as an option.

When combined, these products respond to recent industry trends toward flatter, more distributed control architectures; more powerful devices; and more data handling at the Control layer of the communication architecture. You use products to communicate on a ControlNet link.



For information on this product	Catalog Number	See Page
PLC-5/20C, -5/40C, and -5/80C programmable controllers	1785-L20C15, -L40C15, -L80C15	29
Flex I/O adapter module	1794-ACN15, -ACNR15	32
1771 adapter module	1771-ACN15, -ACNR15	34
RS-232-C/parallel interface	1770-KFC15, -KFCD15	36
ISA/EISA bus interface	1784 -KTCX15	38
RSNetWorx™ for ControlNet configuration software	9356-CNETL3	40
RSLinx™ software	9355-WAB	41
RSLogix5™ programming software	9324-RL5300END 9324-RL5300ENE	42



Requirements for implementing a ControlNet release 1.5 and later system:

- Products supporting release 1.5
- RSLinx communication software
- RSNetWorx for ControlNet configuration software
- RSLogix5 programming software (for PLC-5)
- Windows NT® (4.0 or later) or Windows 95® operating system

ControlNet Features

- Eliminates the need for block-transfer programming when communicating with 1771 I/O modules on the ControlNet network
- Compatible with 1771 and 1794 series I/O on the ControlNet network
- Has ControlNet port for programming and peer-to-peer communication
- Supports redundant media operation, which increases ControlNet network reliability

Product Features

- DH+ and remote I/O ports (channels 1A and 1B) in addition to a ControlNet port
- Ethernet connectivity available by using the Ethernet Interface module
- Configurable RS-232-C/423-A port
- Common instruction set between controllers
- Multiple programming language support (structured text, sequential function charts, and ladder logic)
- Advanced instruction set including file handling, sequencer, diagnostic, shift register, immediate I/O, and program-control instructions
- Processor Input Interrupts and global status flags
- Programmable fault response
- Timed-interrupt routine for examining specific information at specific time intervals

PLC-5 Programmable Controllers

The ControlNet PLC-5 programmable controllers (1785-L20C15, -L40C15, -L80C15) are single-slot processors used for control and information processing on a ControlNet link.



These processors offer advanced programming features and versatile communication options to fit your unique application needs.

You can have multiple ControlNet PLC-5 processors on a ControlNet network, with each processor controlling its own I/O on the network, and at the same time communicating with each other.

Related Publications

Publication number	Title
1785-6.5.22	ControlNet PLC-5 Programmable Controllers User Manual Phase 1.5
1785-10.6	ControlNet PLC-5 Programmable Controllers Quick Start
1785-6.2-RN1	Enhanced, Ethernet, and ControlNet PLC-5 Programmable Controllers Firmware Release Notes

Ordering Information

When connecting to a ControlNet network, the 1785-L20C15, -L40C15, and -L80C15 require the following:

- One or two (if redundant media system) ControlNet taps—1784-TPS, -TPYS, -TPR, or -TPYR. Refer to page 20.
- 1786-RG6 cable

PLC-5 Processors

1785-L20C15 processor

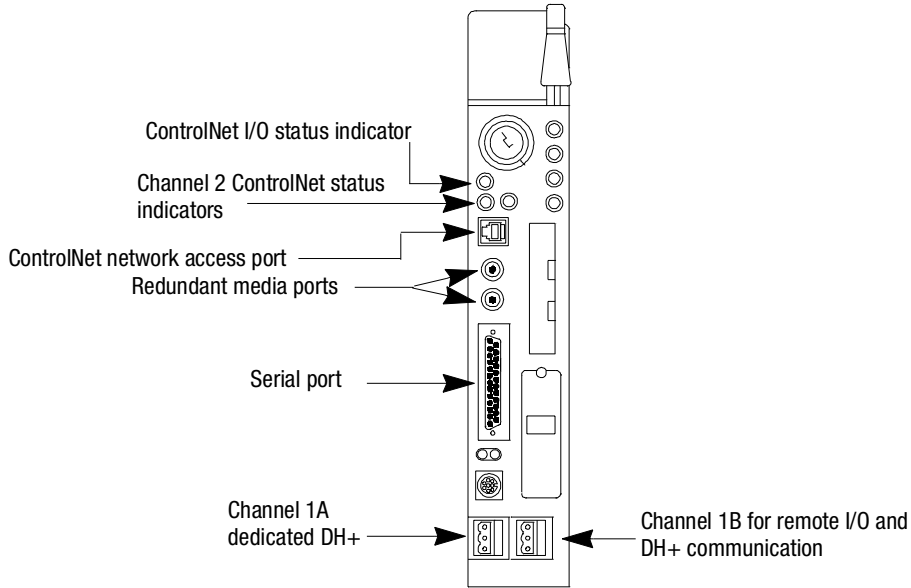

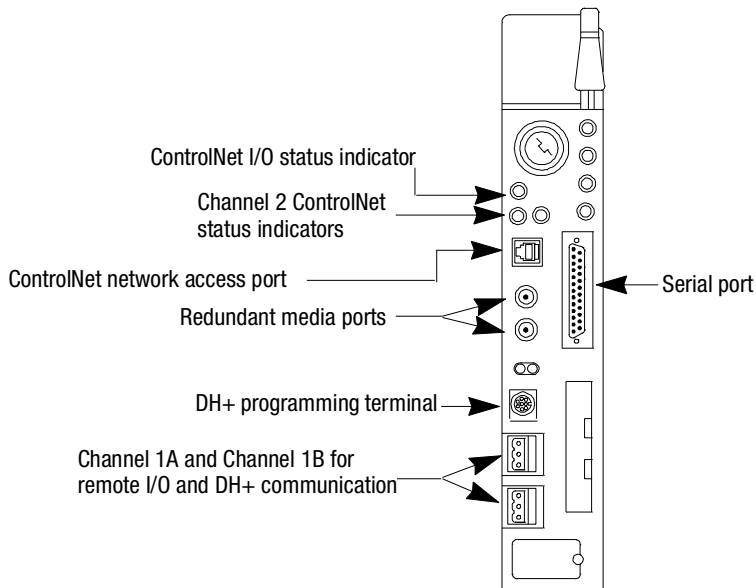

1785-L40C15, -L80C15 processor



30087-M

1785-L20C15, -L40C15, -L80C15 Specifications

Memory modules	<ul style="list-style-type: none"> • 1785-ME16 • 1785-ME32 	1785-ME64 1785-M100		
I/O modules	Bulletin 1771 I/O, 1794 I/O, 1746 I/O, and 1791 I/O including 8-, 16-, 32-pt, and intelligent modules			
Hardware addressing	2-slot <ul style="list-style-type: none"> • Any mix of 8-pt modules • 16-pt modules must be I/O pairs • no 32-pt modules 	1-slot <ul style="list-style-type: none"> • Any mix of 8- or 16-bit modules • 32-pt modules must be I/O pairs 	1/2-slot—any mix of 8-, 16-, or 32-pt modules	
Communication	<ul style="list-style-type: none"> • Serial • DH+ • DH using 1785-KA 	<ul style="list-style-type: none"> • Remote I/O • ControlNet • Ethernet using 1785-ENET 		
		PLC-5/20C	PLC-5/40C	PLC-5/80C
Maximum user memory words			16K	48K ^①
Maximum total I/O	Any Mix	512	2048	3072
	Complimentary	512 in and 512 out	2048 in and 2048 out	3072 in and 3072 out
Program scan time	0.5 ms per K word (bit logic) 2 ms per K word (typical)			
ControlNet I/O	Transmission Rate	5M bit/s		
	Network Update Time (NUT)	2-100 ms (user selectable)		
	Number of ControlNet Ports	1 (redundant)		
	Maximum number of nodes per link with repeaters	99		
	Maximum number of I/O map entries	64	96	128
	Maximum DIF/DOF size	2000 words	3000 words	4000 words
	Maximum scheduled peer-to-peer message size	1-240 words		
Remote I/O and DH+	Transmission Rate	57.6k bit/s 115.2k bit/s 230k bit/s		
	I/O Scan Time (Typical)	10ms per rack @ 57.6k bit/s 7ms per rack @ 115.2k bit/s 3ms per rack @ 230k bit/s		
	Maximum number of Remote I/O racks	3	15	23
	Maximum number of Remote I/O devices	12	60	92
	Number of port configurable for DH+ or Remote I/O (Adapter or Scanner)	1	2	2
	Number of dedicated DH+ ports	1	0	0
Number of serial ports	1			
Number of coprocessor ports	1			
Agency Certification	<ul style="list-style-type: none"> •   Class I, Division 2, Groups A, B, C, D •  marked for all applicable directives 			

^① The PLC-5/40C processor has a limit of 32K words per data-table file.

^② The PLC-5/80C processor has a limit of 56K words per program file and 32K words per data table file. The PLC-5/80C processor has 64K words of total data table space.

FLEX I/O Adapter Module

The ControlNet FLEX I/O adapter (1794-ACN15, -ACNR15) lets you connect the FLEX I/O system to your ControlNet network.



ControlNet Features

- As many as eight FLEX I/O modules can be connected to one ControlNet FLEX I/O adapter
- Interfaces with as many as 128 discrete I/O points (or 64 channels of analog) per adapter to a ControlNet network
- Local communication network access, through the network access port (NAP)
- I/O data connections can be partitioned on a per module or module group basis. Each connection can be scheduled for a different production rate.
- Multiple controllers and terminals can share module input data
- Adapter firmware is fully FLASH upgradable over ControlNet for easy access to new features
- Redundant media support (1794-ACNR15)

Product Features

- Low-cost I/O system
- Individual components let you mix and match I/O types and termination styles
- Diagnostic status indicators for network and I/O
- Remove and insert I/O modules under power
- Small, compact design mounts horizontally or vertically to fit tight space

ControlNet FLEX I/O Adapter Components

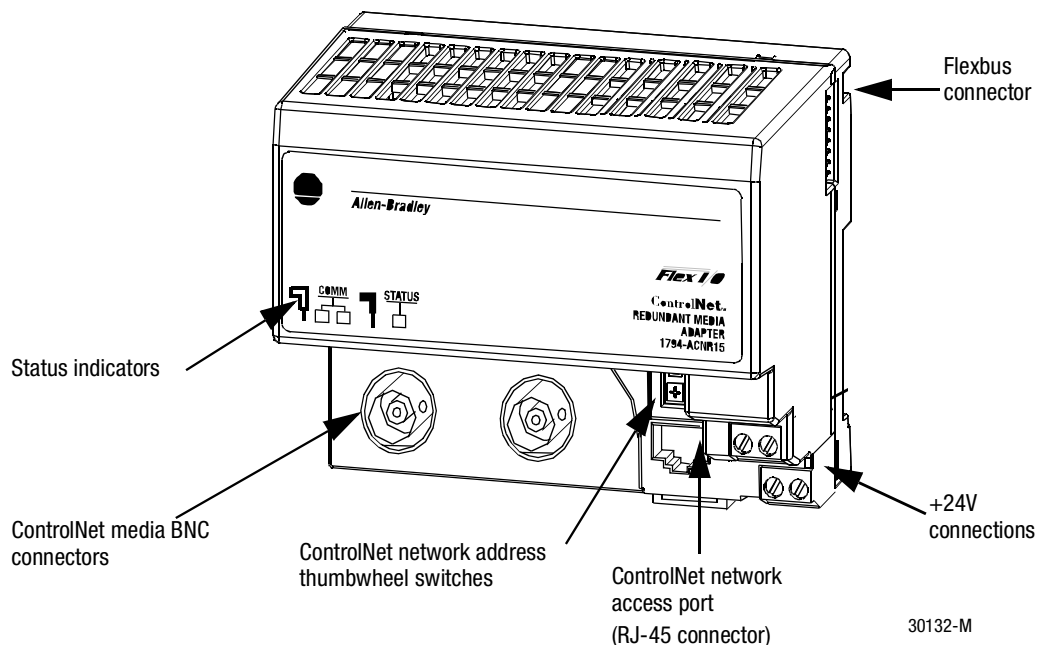



If any part of your network requires redundancy, order 1794-ACNR15. Use 1794-ACN15 only if the entire network is non-redundant.

Related Publications



Publication number	Title
1794-2.1	Flex I/O Product Data
1794-5.47 (ACN15)	Flex I/O ControlNet Adapter Installation Instructions
1794-5.48 (ACNR15)	

Ordering Information

The 1794-ACN15 and -ACNR15 require the following:

- 35 X 7.5 mm DIS Rail (Part Num. 199-DR1; 46277-3; EN50022)
- an approved ControlNet coax tap

1794-ACN15, -ACNR15 Specifications

ControlNet interface	Connectors	1 BNC connector for non-redundant media operation (2 for redundant) 1 NAP (RJ-45 8-pin with shield)
	Cable	quad shield RG-6 coaxial cable
	Ground isolation	transformer
Power conductors	Wire size	12 gauge (4 mm) stranded maximum 3/64 inch (1.2 mm) insulation max.
	category	2 ^①
Electrical	I/O capacity	8 modules
	Input voltage rating	24 V dc nominal
	Input voltage range	19.2 V to 31.2 V dc (includes 5% ac ripple)
	Communication rate	5 mbits/s
	Flexbus output current	640 mA maximum @ 5 V dc
	Isolation voltage	100% tested at 850 V dc for 1 s between user power and flexbus
	Power consumption	400 mA maximum from external 24 V supply
	Power dissipation	4.6 W maximum @ 19.2 V dc
Environmental	Thermal dissipation	15.7 BTU/hr @ 19.2 V dc
	Operational temperature	0 to 55°C (32 to 131°F)
	Storage temperature	-40 to 85°C (-40 to 185°F)
	Relative humidity	5 to 95% (without condensation)
	Shock	operating 30 g peak acceleration, 11 (±1) ms pulse width non-operating 50 g peak acceleration, 11 (±1) ms pulse width
Physical	Vibration	tested 5 g @ 10-500 Hz per IEC 68-2-6
	Dimensions (H x W x D)	87 x 94 x 69 mm 3.4 x 3.7 x 2.7 in
	Weight	0.2 kg (0.4 lb)
Agency certification	<ul style="list-style-type: none"> •   •  marked for all applicable directives 	

^① Use this conductor category information for planning conductor routing. See the *Industrial Automation Wiring and Grounding Guidelines*, publication 1770-4.1.

1771 Adapter Modules

The ControlNet 1771 adapter modules (1771-ACN15, -ACNR15) control remote I/O on a ControlNet link.

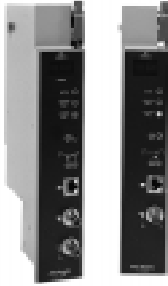

ControlNet Features

- Redundant media support (1771-ACNR15 only)
- Local handling of block transfers to non-discrete I/O modules
- Local communication network access, through the network access port (NAP)
- I/O data connections can be partitioned on a per module or module group basis. Each connection can be scheduled for a different production rate.
- Multiple controllers and terminals can share module input data
- Adapter firmware is fully FLASH upgradable over ControlNet for easy access to new features

Product Features

- 1/2-slot, 1-slot, and 2-slot addressing modes
- Four segment-display and diagnostic status indicators for network address and I/O status indication
- High-speed data transfer
- Local communication network access, through the network access port (NAP)
- Single-slot module

Front panel components

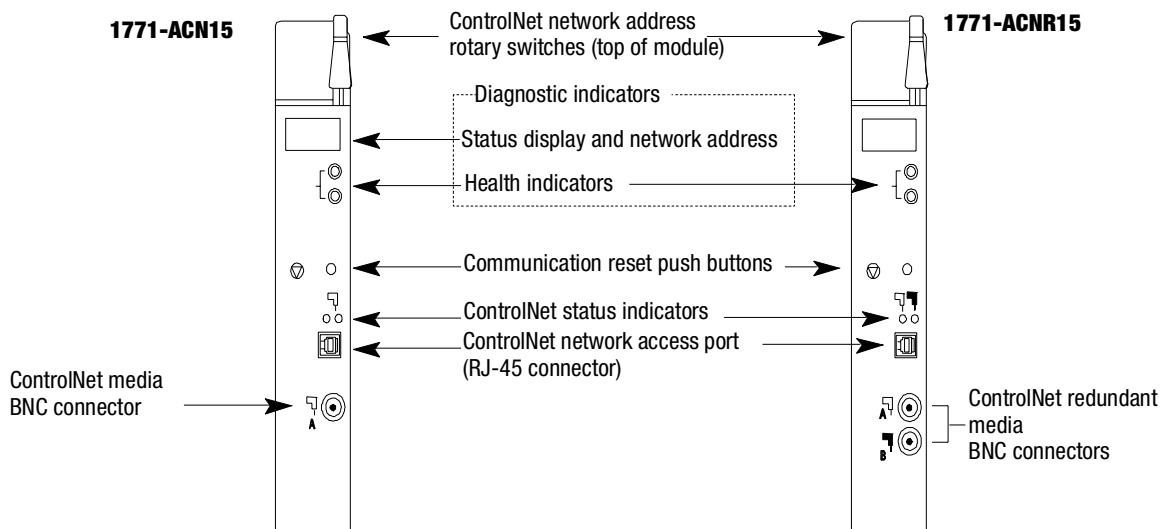

If any part of your network requires redundancy, order 1771-ACNR15. Use 1771-ACN15 only if the entire network is non-redundant.

Related Publications



Publication number	Title
1771-6.5.124	ControlNet Adapter Module User Manual
1786-6.21	ControlNet Cable System Planning and Installation Manual
1786-2.6	ControlNet Network Access Cable Installation Instructions
1770-4.1	Industrial Automation Wiring and Grounding Guidelines

Ordering Information

The 1771-ACN15 and -ACNR15 require one the following I/O chassis types:

- 1771-A1B
- 1771-A2B
- 1771-A3B
- 1771-A3B1
- 1771-A4B

1771-ACN15, -ACNR15 Specifications

ControlNet interface	Connectors	1771-ACN15 1 BNC connector for non-redundant media operation 1 NAP (RJ-45 8-pin with shield) 1771-ACNR15 2 BNC connectors for redundant media operation 1 NAP (RJ-45 8-pin with shield)
	Cable	quad shield RG-6 coaxial cable
	Ground isolation	transformer
	Electrical	Power dissipation
	Thermal dissipation	17.06 BTU/hr
	Backplane current	1.0 A @ 5 V
Environmental	Operational temperature	0 to 60°C (32 to 140°F)
	Storage temperature	-40 to 85°C (-40 to 185°F)
	Relative humidity	5 to 95% (without condensation)
Physical	Location	1771 I/O chassis, leftmost slot
	Keying	upper connector: between 54 and 56 lower connector: between 16 and 18
	Weight	1.13 kg (2 lb 8 oz)
Agency certification		<ul style="list-style-type: none"> •   •  marked for all applicable directives

RS-232-C/Parallel Interface

The ControlNet communication interface module (1770-KFC15, -KFCD15) lets you connect serial devices to a ControlNet network via a serial or parallel interface.

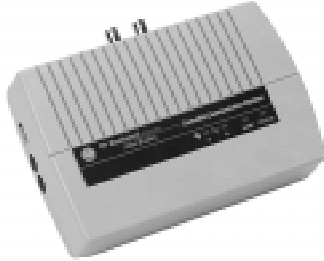

ControlNet Features

- Includes a network access port for ControlNet communication as well as redundant media BNC ports, an RS-232-C serial port, and a parallel port

Product Features

- Available for ac (1770-KFC15) or dc (1770-KFCD15) power
- Push buttons with seven-segment indicators to set and verify network address and serial RS-232-C or parallel communication parameters
- Supports these RS-232-C communication rates: 300, 600, 1200, 2400, 4800, 9600, 19200, and 38400 bits/s
- Parameter settings are saved in non-volatile memory; you do not lose them if power to the module is interrupted
- Emulates a 1770-KF2 for easy migration from DH+ applications currently using a 1770-KF2

Related Publications



Publication number	Title
1770-6.5.20	ControlNet Communication Interface Module User Manual

Ordering Information

The 1770-KFC15 and -KFCD15 require the following:

- approved coax tap (refer to page 20)
- standard BNC connectors—RG6 type coax cable

1770-KFC15, -KFCD15 Specifications

ControlNet interface	Connectors	2 BNC connectors for redundant media operation 1 NAP (RJ-45 8-pin with shield)
	Cable	quad shield RG-6 coaxial cable
	Ground isolation	transformer
RS-232-C interface	Start bits	1
	Data bits	8
	Parity	none, even, odd
	Stop bits	1
	Communication rates	300, 600, 1200, 2400, 4800, 9600, 19200, 38400
	Connector	DB-25P (male)
	Output	RS-232-C
	Protocol	Allen-Bradley DF1
	Cable length	recommended maximum of 7.5 m (25 ft) at 38400 baud, or 15 m (50 ft) at lower baud rates
	Cable type	shielded
Parallel port interface	Connector	DB-25 (female)
	Data format	DF1 nibble or DF1 byte transfers with handshaking
	Cable length	recommended maximum of 3 m (10 ft)
	Cable type	shielded
Electrical	Voltage	1770-KFC15 - 115/230V ac 1770-KFCD15 - 18 to 40V dc
	Frequency	50/60 Hz (1770-KFC15 only)
	Power	23 W
	Fusing	1770-KFC15 - double-fused - UL 198G and CSA 22.2, No. 59 rated, 5 mm x 20 mm 1770-KFCD15 - 5mm x 20mm 0.5A, slow blow, 250V fuses
Environmental	Operating temperature	0 to 60°C (32 to 140°F)
	Storage temperature	-40 to 85°C (-40 to 85°F)
	Operating humidity	5 to 95% (without condensation)
Physical	Dimensions (H x W x D)	5.1 x 11.7 x 17.8 cm 2 x 4.6 x 7 in
	Weight	0.9 kg (2 lb) approximately
	Mounting	table-top wall/bracket mount
Agency certification	<ul style="list-style-type: none"> •   •  marked for all applicable directives 	

ISA/EISA Bus Interfaces

The ControlNet ISA/EISA 32-bit, bus interface (1784-KTCX15) lets your ISA/EISA-compatible computer communicate on a ControlNet link.



ControlNet Features

- Local communication network access, through the network access port (NAP)
- Redundant media support using BNC connection to coax media

Product Features

- Connects programming terminals to the network
- Connects other software applications to the network
- Network diagnostic status indicators
- Emulates a 1784-KT card for easy migration from DH+ applications currently using a 1784-KT card

Related Publications

Publication number	Title
1784-5.20	ControlNet Communication Interface Card Installation Instructions
1784-5.20-RN1	ControlNet Communication Interface Card Release Notes

Ordering Information

The 1784-KTCX15 require the following:



- 16-, or 32-bit ISA/EISA expansion slot
- 1786-CP cable (for NAP port)
- **RSLinx** software (refer to page 41)
- approved tap for coax media

Front panel components

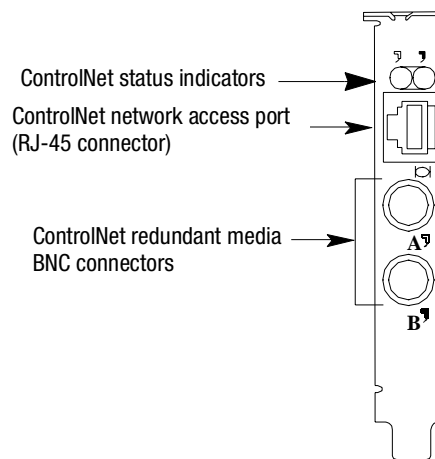
1784-KTCX15



1784-KTCX15 Specifications

ControlNet interface	Connectors	2 BNC connectors for redundant media operation 1 NAP (RJ-45 8-pin with shield; opto-isolated)
	Cable	quad-shield RG-6 coaxial cable
	Ground isolation	transformer
Environmental	Operational temperature	0 to 50°C (32 to 122°F)
	Storage temperature	-40 to 85°C (-40 to 185°F)
	Relative humidity	5 to 95% (without condensation)
	Shock	30 g peak/11 ms
	Vibration operating	10 to 150 Hz, constant 0.012 in displacement 10 to 150 Hz, constant 2.0 g acceleration
Physical	Card location	16-bit ISA- or 32-bit EISA-compatible computer
Agency certification		<ul style="list-style-type: none"> •   •  marked for all applicable directives

RSNetWorx for ControlNet Configuration Software

RSNetWorx (9357-CNETH3) for ControlNet is a 32-bit graphical network configuration tool supporting ControlNet Release 1.5 and later. The network oriented view of RSNetWorx provides the information and tools needed to configure a ControlNet network. **RSNetWorx** offers a graphical view of the network, improved scheduling of bandwidth usage, and both offline and online capabilities.

ControlNet Features

- Configures network-wide parameters such as Network Update Time (NUT) and Maximum Scheduled Node Address
- Schedules I/O data transfers and peer-to-peer messaging
- Provides a seamless interface to the PLC-5 ControlNet Channel Configuration in RSLogix5 and RSLogix Frameworks
- Provides feedback on bandwidth usage

Product Features

- Allows for import of electronic data sheets (EDS) for support of new ControlNet products from Allen-Bradley or other vendors
- Interfaces with **RSLink** for network communication on Windows NT or Windows 95 system
- Uses **RSLogix5** or **RSLogix Frameworks™** for setting up the I/O and peer-to-peer data owned by a particular ControlNet PLC-5 on the network.

Ordering Information

To use **RSNetWorx** successfully, you need to install the following software:

- **RSLogix5** (refer to page 42)
- **RSLink** (refer to page 41)

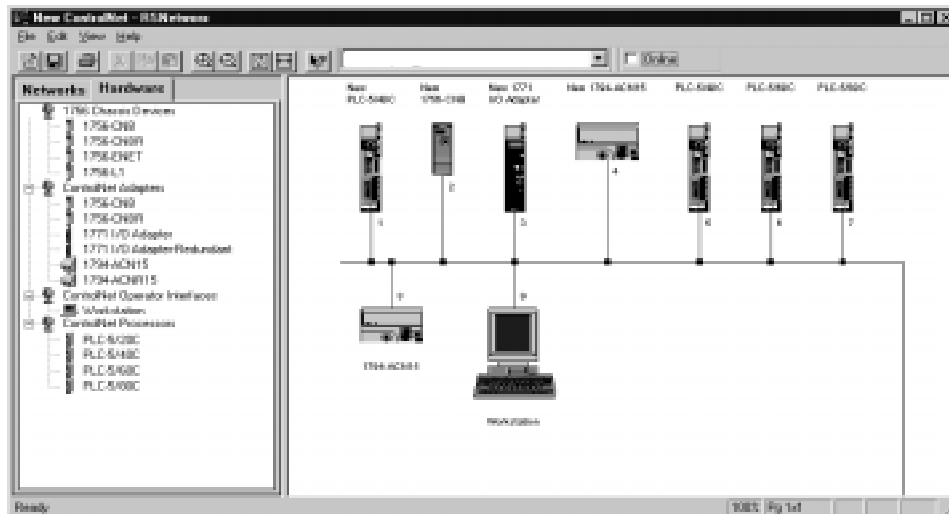

ControlNet Features

- Allows communication to nodes on the ControlNet network through applications created using Visual C++ or Visual Basic
- Offers direct driver connections to PLC processors
- Contains drivers for the 1784-KTC15 ISA bus interface card

Product Features

- Includes the functionality of **RSLink OEM**, and the DDE communication to all products that can act as DDE clients such as Microsoft Excel™ for support of non-Allen-Bradley products
- Contains a development kit for creating custom applications that use the C API communication capabilities of **RSLink** and **RSLink OEM** software

RSLink Software

RSLink software (9355-WAB) is a complete 32-bit product family that provides communication to a range of applications.

RSLink provides plant-floor data to DDE client applications for displaying, logging or trending. You can set individual parameters from a supervisory computer.

Related Publications

Publication number	Title
9398-WAB32TD	RSLink Technical Data Sheet
9399-WAB32UG	RSLink User's Guide

Ordering Information

RSLink is compatible with the following software:

- PLC-5 A.I Series™ programming software
- **RSLogix 5** software
- **RSView**™ software
- **RSTrend**™ software
- WINtelligent™ QUALITY and RECIPE software

System Requirements

- Microsoft Windows NT (4.0 or greater) or Windows 95
- RAM requirements vary depending upon the application
- Ethernet card and/or an A-B communication device or cable, depending upon the application



It is possible to receive a bundled package (**RSWorx** for ControlNet) of the three software packages used with a ControlNet system. The software package (catalog no. 9324-RWCNTENE) contains the following:

- **RSNetWorx**
- **RSLogix5**
- **RSLink (Lite)**

RSLogix5 Programming Software

RSLogix5 software is the first 32-bit, Windows 95 and Windows NT™-compatible programming software package in the PLC industry. The software is designed to be simple, intuitive (editing with drag and drop functionality), display superior diagnostics, and present reliable communications. All project information is consolidated and displayed as a “project tree”, providing easy point and click capabilities.

ControlNet Features

- Used for programming many types of controllers including Allen-Bradley's ControlNet PLC-5
- Compatible with existing projects created in Rockwell Software's MS-DOS-based A.I. Series, Ladder Logistics™, and Advanced Programming Software™ (APS packages)
- Easy-to-use configurator allows for drag and dropping modules from a list for assignment to a slot in a configuration
- Contains a consolidated project view
- Contains a database editor which allows for the creating of a list to easily address instructions in your ladder logic through symbols and addresses
- ControlNet channel configuration using the PLC-5C ControlNet Configuration tool



System Requirements

Operating system	Processor	Memory	Hard disk space	Graphics adapter
Windows 95	486/66 (Pentium recommended)	16Mb RAM (32Mb recommended)	8Mb disk space	VGA Graphics Adapter 640X480 (800X600 recommended)
Windows NT 4.0	486/66 (Pentium recommended)	16Mb RAM (32mb recommended)	8Mb disk space	VGA Graphics Adapter 640X480 (800X600 recommended)

CIO instructions (ControlNet Input/Output instructions)

Instructions used on a ControlNet link to perform unscheduled non-discrete I/O data transfers.

configuration manager node

The node responsible for distributing ControlNet configuration data to all nodes on the network.

ControlNet network

A communication architecture that allows the exchange of messages between Allen-Bradley Company, Inc. products and certified third-party products.

connection

An opened communication path between two nodes on a ControlNet network.

ControlNet status indicators

Channel A and channel B indicators on your node indicating status on the ControlNet link.

DF1 protocol

A peer-to-peer link-layer protocol that combines features of ANSI X3.28-1976 specification subcategories D1 (data transparency) and F1 (two-way simultaneous transmission with embedded responses).

DH+ network

Data Highway Plus network. An Allen-Bradley local area network made up of one or more token-passing baseband links.

DIF (Data Input File)

Integer file used by ControlNet PLC-5 processors to store discrete and non-discrete input data. DIF cannot be forced.

DOF (Data Output File)

Integer file used by ControlNet PLC-5 processors to store discrete and non-discrete output data. DOF cannot be forced.

discrete I/O data transfer

A type of data transfer in which single units of I/O have discrete relationships with values in the processor's data table; uses either the processor's input- and output-image tables or DIF/DOF; discrete I/O mapped to DIF/DOF cannot be forced, configured on a per-node basis in ControlNet I/O map table.

drop cable

A cable that connects a node to the trunk cable. This is an integral part of Allen-Bradley 1786 taps.

C**glossary**

Refer to this glossary for ControlNet network term and abbreviation definitions.

D

frame

A single data transfer on a ControlNet link.

IDI instruction (Immediate Data Input instruction)

An I/O instruction used on a ControlNet link to transfer as many as 64 words of non-discrete input data. In an IDI, the most recent data is copied from the private memory buffer to a user-specified data-table address.

IDO instruction (Immediate Data Output instruction)

An I/O instruction used on a ControlNet link to transfer as many as 64 words of non-discrete output data. In an IDO, the data is copied from a user-specified area to the private memory buffer and sent on the next I/O update.

IIN instruction (Immediate INput instruction)

An I/O instruction used on a ControlNet link to transfer one word of discrete input data. An IIN uses the most recent copy of the specified input word secured in the last discrete I/O data transfer from the corresponding I/O chassis. This value is moved from the private memory buffer to the working data table and is used in all subsequent ladder instructions.

IOT instruction (Immediate OuTput instruction)

An I/O instruction used on a ControlNet link to transfer one word of discrete output data. In an IOT, the current state of the specified output word is copied to the private memory buffer and is used on the next output update to the I/O chassis.

I/O map table

A table that you configure with the programming software to map data from an I/O chassis and other devices on the ControlNet network to particular data-table file addresses.

link

A collection of nodes with unique addresses (in the range of 1-99). Segments connected by repeaters make up a link; links connected by bridges make up a network.

map-table entry

One entry in the I/O map table that you configure with the programming software to map data from one I/O chassis (or other device on a ControlNet link) to particular data-table file addresses.

maximum scheduled node

The node with highest network address that can use *scheduled* time on a ControlNet link.

F
I**L****M**

maximum unscheduled node

The node with highest network address that can be *unscheduled* time on a ControlNet link.

MSG instructions (MeSsaGe instructions)

Instructions used by ControlNet PLC-5 processors for peer-to-peer communication.

NAP (Network Access Port)

A port that provides a temporary network connection through an RJ-45 connector.

N**network**

A series of nodes connected by some type of communication medium. The connection paths between any pair of nodes can include repeaters, routers, bridges, and gateways.

network address

A node's address on the network.

node

The port of a physical device connected to the network that requires a network address to function on the network. A link may contain a maximum of 99 nodes.

non-discrete I/O data transfer

Type of data transfer in which blocks of data transferred to or from I/O modules using either DIF/DOF or the processor's input- and output-image tables (I/O files); scheduled transfers are configured in the ControlNet I/O map table, unscheduled transfers make use of ControlNet I/O (CIO) transfer instructions.

NUI (Network Update Interval)

A single occurrence of the network update time (NUT).

NUT (Network Update Time)

Repetitive time interval in which data can be sent on the ControlNet network.

parallel port

An input/output port for a device that transmits multiple data and control bits over wires connected in parallel.

P**PCCG**

Programmable Controller Communication Commands. An application-level command set that Allen-Bradley programmable controllers use to communicate across networks.

redundant media

A dual cable system that lets you receive the best signal over a network.

R**repeater**

A two-part active physical-layer device that reconstructs and retransmits all traffic it hears on one segment to another segment.

remote I/O link

A serial link for carrying I/O data between a PLC or SLC processor/scanner and remote I/O adapters.

RS-232-C port

A serial port that complies with accepted industry standard for serial binary communication circuits in a point-to-point link.

scheduled transfers

Deterministic and repeatable transfers that are continuous and asynchronous to the ladder-logic program scan.

S**segment**

Trunk-cable sections connected via taps with terminators at each end; a segment does not include repeaters.

serial port

A port that transmits/receives data and control bits sequentially over a single transmission line (*see RS-232-C port*).

tap

A component that connects products to the ControlNet trunk cable. A tap is required for each node and for both sides of each repeater.

T**terminator**

A 75- Ω resistor (mounted in a BNC plug) placed on the ends of segments to prevent reflections from occurring at the ends of cables.

trunk cable

The bus or central part of the ControlNet cable system.

trunk-cable section

The length of trunk cable between any two taps.

unscheduled transfers

Non-deterministic data transfers through ladder-initiated communication or programming devices.

U

© 1997 Allen-Bradley Company, Inc.

ControlNet is a trademark of ControlNet International.

A.I. Series, Data Highway Plus, DH+, FLEX I/O, PLC, PLC-5/20, PLC-5/40, PLC-5/80 are trademarks of Rockwell Automation.

RSLinx, RSLogix Frameworks, RSLogix5, and RSNetWorx are trademarks of Rockwell Software.

DeviceNet is a trademark of Open Device Vendors Association (O.D.V.A.)

Ethernet is a trademark of Digital Equipment Corporation, Intel, Xerox Corporation.

Windows, Windows Excel, Windows NT, and Windows 95 are trademarks of Microsoft Corporation.



Allen-Bradley

Allen-Bradley, a Rockwell Automation Business, has been helping its customers improve productivity and quality for more than 90 years. We design, manufacture and support a broad range of automation products worldwide. They include logic processors, power and motion control devices, operator interfaces, sensors and a variety of software. Rockwell is one of the world's leading technology companies.



Worldwide representation.

Argentina • Australia • Austria • Bahrain • Belgium • Brazil • Bulgaria • Canada • Chile • China, PRC • Colombia • Costa Rica • Croatia • Cyprus • Czech Republic • Denmark • Ecuador • Egypt • El Salvador
Finland • France • Germany • Greece • Guatemala • Honduras • Hong Kong • Hungary • Iceland • India • Indonesia • Ireland • Israel • Italy • Jamaica • Japan • Jordan • Korea • Kuwait • Lebanon
Malaysia • Mexico • Netherlands • New Zealand • Norway • Pakistan • Peru • Philippines • Poland • Portugal • Puerto Rico • Qatar • Romania • Russia-CIS • Saudi Arabia • Singapore • Slovakia
Slovenia • South Africa, Republic • Spain • Sweden • Switzerland • Taiwan • Thailand • Turkey • United Arab Emirates • United Kingdom • United States • Uruguay • Venezuela • Yugoslavia

Allen-Bradley Headquarters, 1201 South Second Street, Milwaukee, WI 53204 USA, Tel: (1) 414 382-2000 Fax: (1) 414 382-4444